

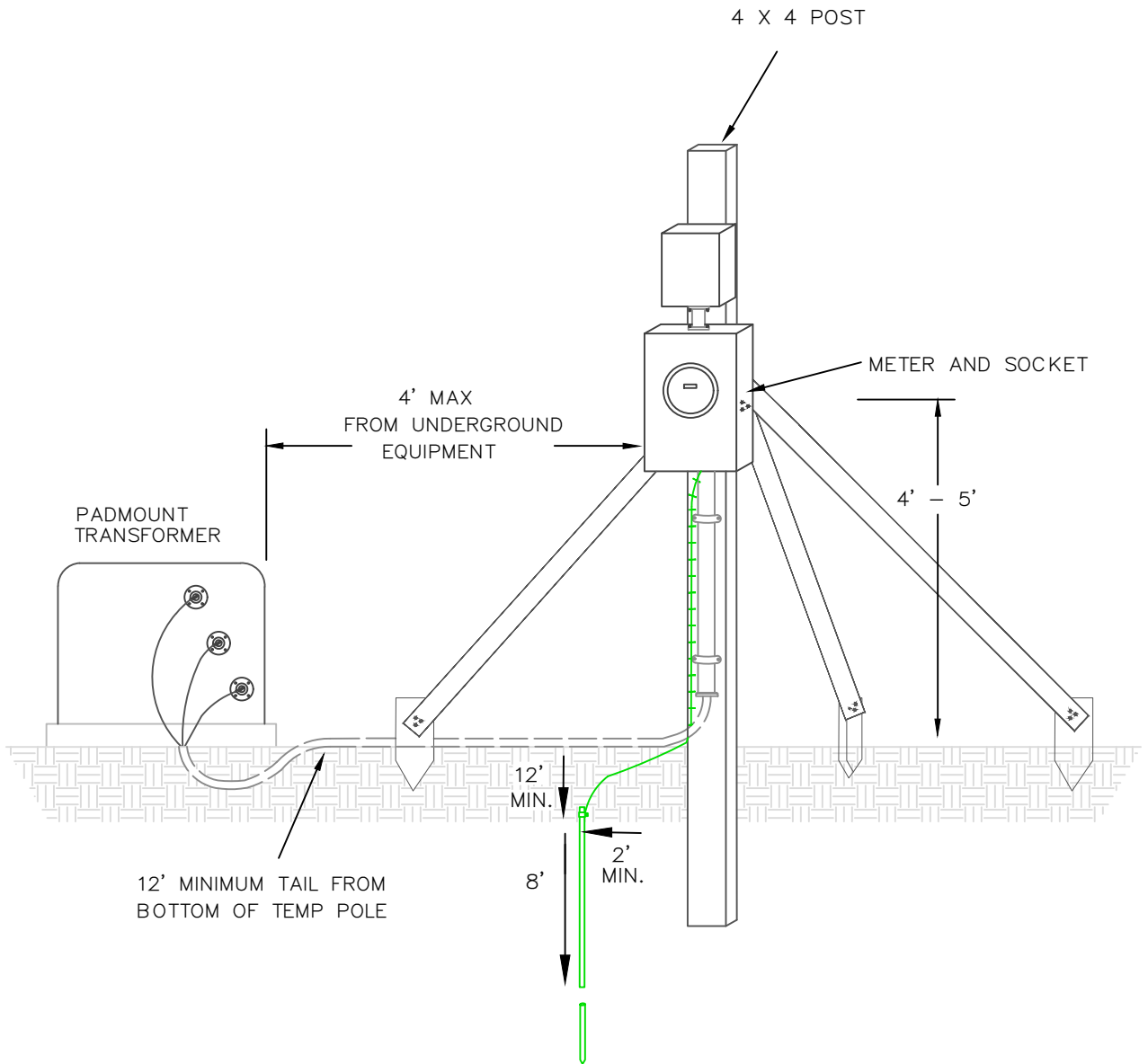

## REQUESTING SERVICE FOR TEMPORARY CONSTRUCTION METERS

- ▶ Address must be acquired for each location prior to meter request.
- ▶ Contact GVEC Customer Service Representative at 800.223.4832 with billing and address information.
- ▶ Electrician to set approved temporary meter structure in proper location prior to request.
  - Proper location is immediately adjacent to transformer or pedestal providing power.
  - Temporary meter structure must be marked with address.
  - City inspection is required if within city limits.
- ▶ Once GVEC is notified of city inspection (where applicable), GVEC personnel will set temporary meter within 7-10 days.
- ▶ If temporary meter is deemed "out of spec" by GVEC lineman, a \$50 trip charge will be applied to account and meter must begin inspection process again.



BUILD IN ACCORDANCE WITH LOCAL BUILDING CODES

GUADALUPE VALLEY ELECTRIC COOPERATIVE				
TEMPORARY SERVICE FROM UNDERGROUND DISTRIBUTION				
 INTERNET   ELECTRIC   HOME			TEMP URD	
DATE	REVISED BY	DATE		REVISED BY
3-24-2017	GB	6-21-2017		GB
4-11-2017	GB	9-19-2022		SAL

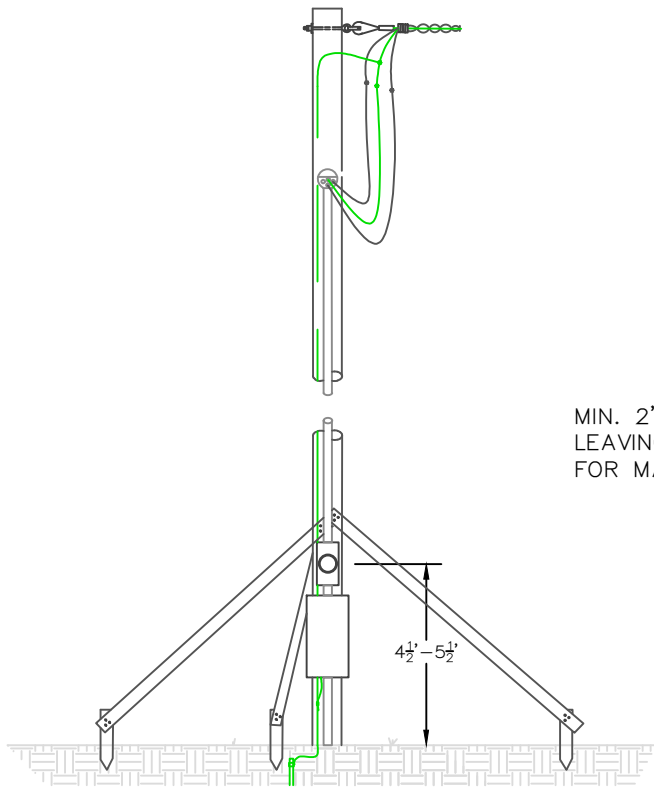

PLACE TEMP POLE MAX OF 20'  
FROM GVEC ELECTRIC POLE

MIN. 2' OF TAIL WIRE  
LEAVING WEATHER HEAD  
FOR MAKE-UP

4½' - 5½'

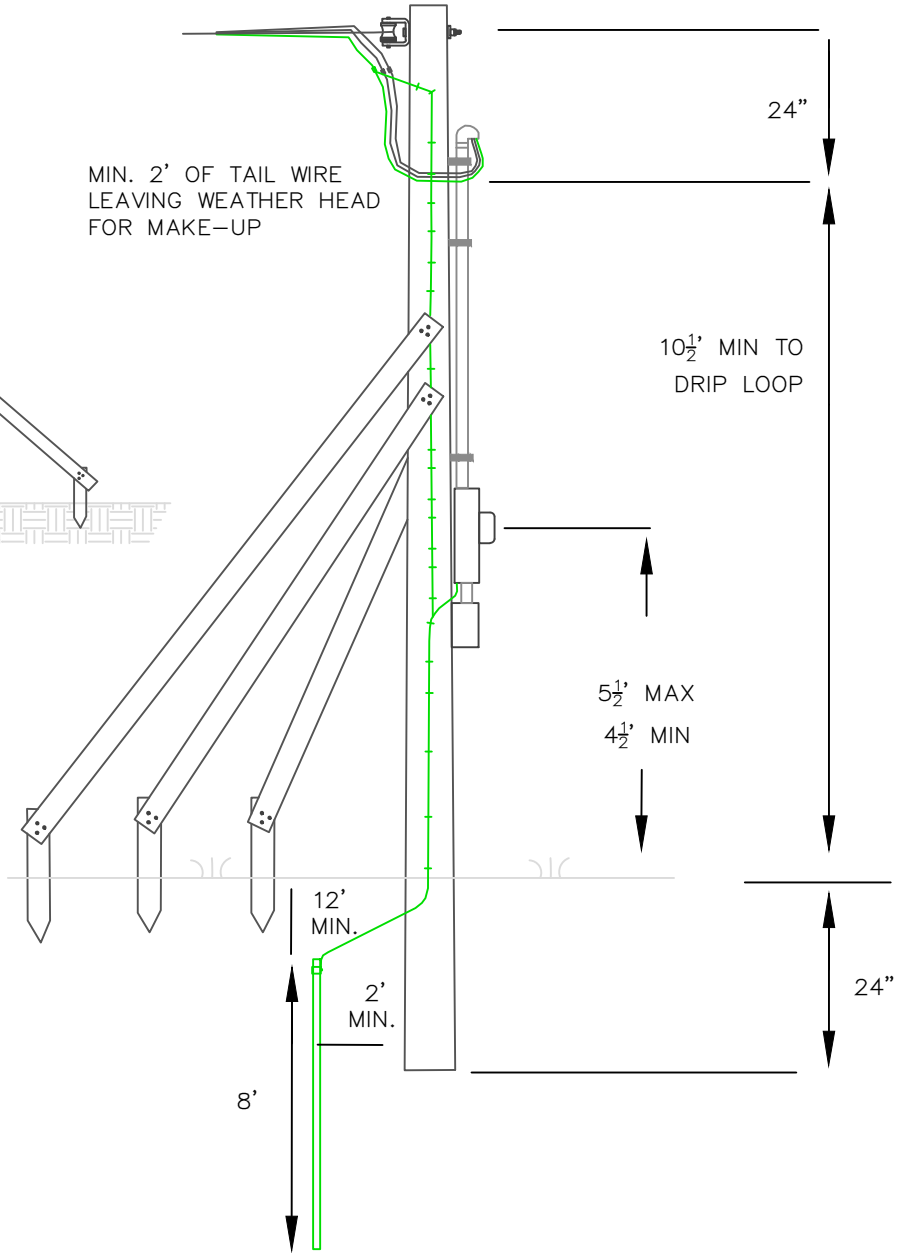

24"

10½' MIN TO  
DRIP LOOP

5½' MAX  
4½' MIN

12' MIN.

2' MIN.

24"

8'

BUILD IN ACCORDANCE WITH  
LOCAL BUILDING CODES

RISER MATERIAL CONDUIT  
MUST BE RIDGED ALUMINUM  
OR STEEL.

GUADALUPE VALLEY ELECTRIC COOPERATIVE

TEMPORARY SERVICE FROM  
OVERHEAD DISTRIBUTION



INTERNET | ELECTRIC | HOME

TEMP SVC

DATE	REVISED BY	DATE	REVISED BY
2-17-2017	GB	3-27-2023	SAL
6-20-2017	GB		