

REQUIREMENTS FOR ELECTRIC UTILITY ROAD CROSSINGS

All road crossings must be installed according to GVEC's electrical design.

All road crossings must be inspected by a GVEC representative before being backfilled.

- ▶ All road crossing conduit material is supplied by developer.
- ▶ Only 2 ½-inch or 4-inch (as called for on approved design) Schedule 40 gray electrical conduit is to be used.
- ▶ All joints of placed conduits must be glued during installation.
- ▶ All road crossing conduits must be covered with red burial warning tape 12 inches above conduit.
- ▶ Road crossing conduits must be installed with minimum of 48 inches of cover at final grade.
- ▶ Conduits should be laid flat in the trench, side by side, as shown in the typical—*not* stacked or twisted. If more than two pipes are in a trench, they must be numbered on the inside, bottom of each pipe (ex: 1, 2, 3, etc.).
- ▶ 4-inch conduit, when called for, will be laid flat, side-by-side in the bottom of the trench. If more than two pipes are in a ditch, you must number the inside, bottom of each pipe (ex: 1,2,3, etc.). The 2 ½-inch may be stacked on top of the 4-inch with a minimum of 4 inches separation between them, but still require 48 inches of cover at final grade to the top set of crossing pipes.
- ▶ When electrical crossings are required to cross water mains, they must be 2 feet below or 2 feet above water mains. Conduits still require 48 inches of cover at final grade. (Pit sand may be required by some water utilities.)
- ▶ All other utilities must maintain a minimum of 3 feet of separation from the electrical crossing trench.
- ▶ No other utility crossings may be stubbed out in front of electric transformers or switches.
- ▶ No other utilities may share the same trench as the electric conduits.
- ▶ All crossings are to be installed at the property line unless water meters are at the crossing location. At locations where water meter conflicts exist, the electrical crossing must be moved 7 feet from the property line to avoid water meters. All other utility crossings must be located 3 feet on opposite side of property line.
- ▶ Crossings must be installed at all drainage channels.
- ▶ Property pins/stakes must be set at both ends of crossing for verification of correct location.

**ALL CROSSINGS MUST BE INSPECTED BY A GVEC REPRESENTATIVE BEFORE THEY ARE BACKFILLED.
PLEASE PROVIDE ONE WEEK NOTICE AS TO WHEN INSPECTIONS WILL BE NEEDED.**

SEND EMAIL TO UGCROSSINGS@GVEC.ORG TO SCHEDULE INSPECTIONS

SPANISH VERSION AVAILABLE UPON REQUEST



GVEC TRENCH TYPICALS

Typical Trench With
2 1/2" and 4" Conduits

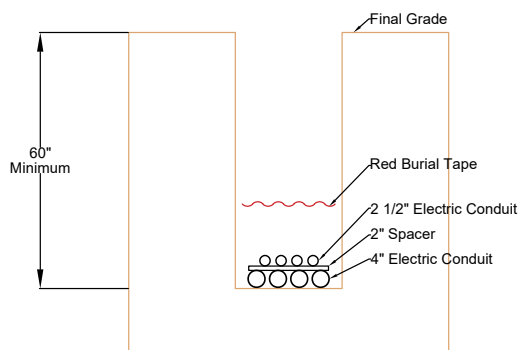

Typical Trench With
2 1/2" Conduits

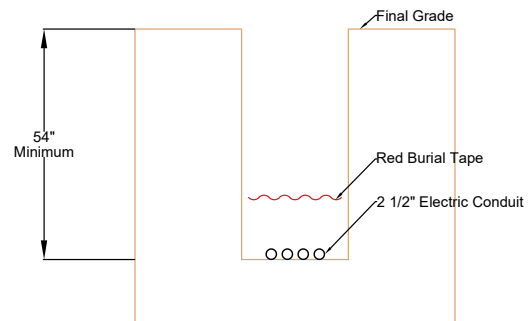

TYPICAL CROSSING
PLACEMENT AT
INTERSECTION

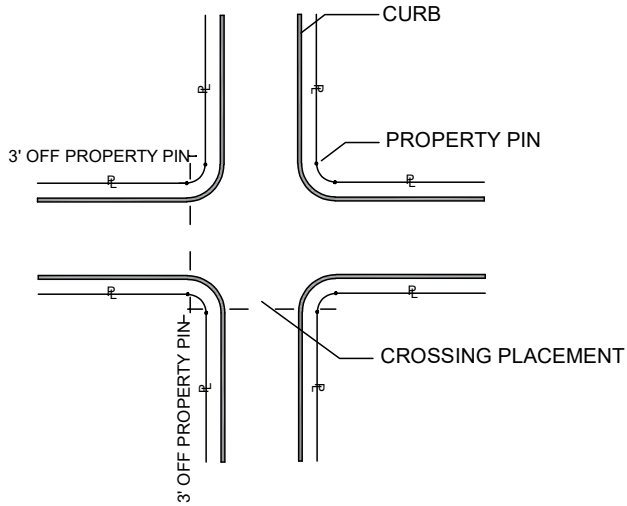

TYPICAL CROSSING
AT PROPERTY LINE WITH
NO WATER METERS OR FIRE PLUG

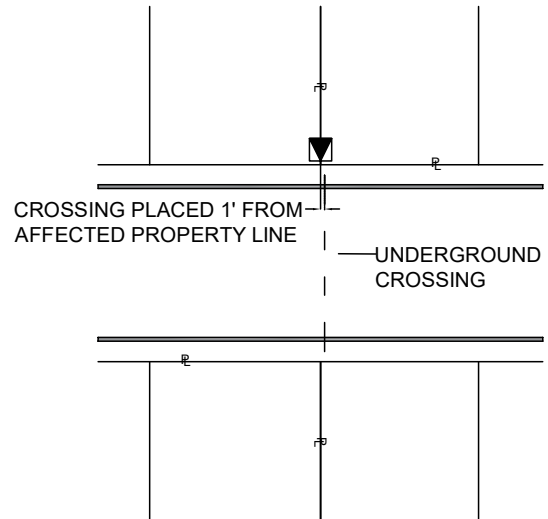

TYPICAL CROSSING
PLACEMENT AT
DRAINAGE OUTLET

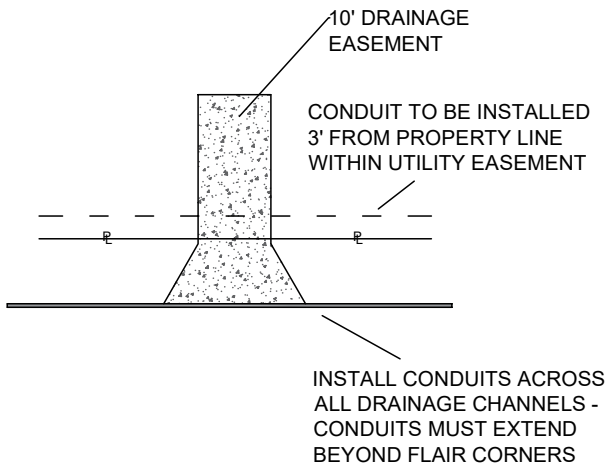

TYPICAL CROSSING
AT PROPERTY LINE WITH
WATER METERS OR FIRE PLUG

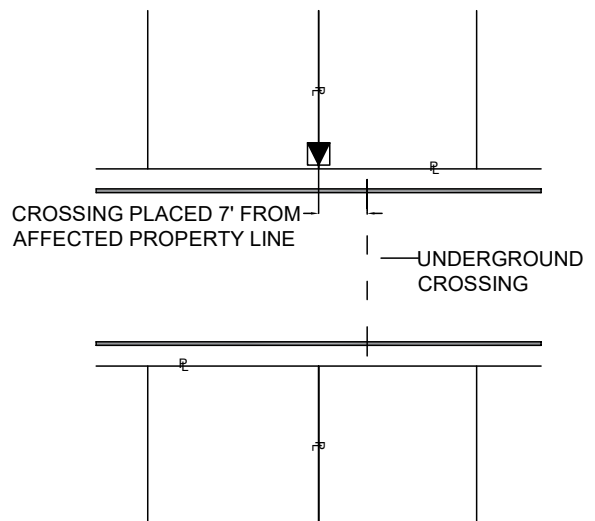

TYPICAL CROSSING
AT PROPERTY LINE WITH
PRIMARY AND SECONDARY CONDUITS

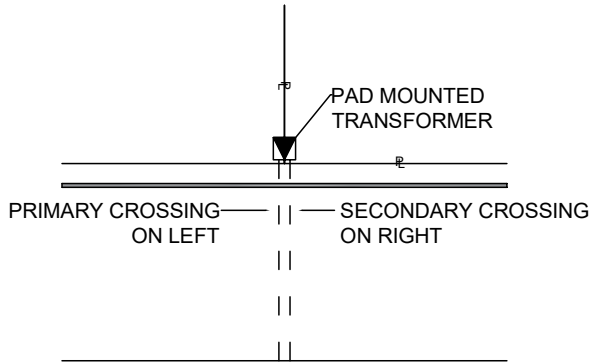

TYPICAL CROSSING
AT PROPERTY LINE WITH
PRIMARY CONDUITS

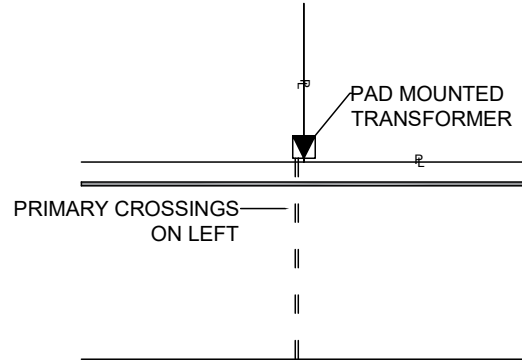

TYPICAL CROSSING
AT PROPERTY LINE WITH
SECONDARY CONDUITS

