

DELIVERING MORE.

MULTI-FAMILY RESIDENTIAL DEVELOPER'S PACKAGE



Unrivaled Quality and
Service Since 1938.

gvec.org

gvec
Delivering more.

ELECTRICITY

Internet | AC/Heating | Electrician Services | Solar & Battery | Community

WELCOME TO GVEC!

The Guadalupe Valley Electric Cooperative (GVEC) was founded in 1938 by a group of rural residents in the Cost area who needed electricity for their farms. On April 5, 1939, the Rural Electrification Administration approved the first loan to the Cooperative to be used in building rural electric lines. Construction began in May 1939, and eight months later, the first GVEC lines went into service.

GVEC provides affordable, reliable electric service to more than 100,000 rural, residential, commercial and industrial meters in South Central Texas. With headquarters in Gonzales and four area offices in the cities of Schertz, Seguin, La Vernia and Cuero, GVEC's service area spans 3,500 square miles across 13 counties. Through technological advancements, well-maintained systems and progressive planning, our goal is to continue to exceed member expectations—a goal we have focused on for over 80 years.

GVEC provides this packet to all developers and their agents, and it should be used as a guide in planning the installation of electric and fiber for receiving electrical power from GVEC's distribution system.

The information presented is subject to change and will be revised periodically to reflect any changes that may develop. Please refer to our website at gvec.org for additional information as well as an online version of this packet.

We look forward to working with you as your electricity provider. If you are looking to provide your customers with the most value from your developments, talk to us about our beyond the meter services including AC/Heating, solar and battery storage, electrician services, and high speed internet. We would appreciate the opportunity to help you beyond electricity!

Thank you,
The GVEC Development Group

TABLE OF CONTENTS

OVERVIEW AND SCOPE OF WORK

Step 1- Submittals to initiate Electric Design	4
Application for Residential or Commerical Development	5
Multi-Family Notes Page	6
Multi-Family Inclusions and Exclusions	7
Step 2- Developer Responsibilities After Approved Design	8

SPECIFICATIONS

Requirements for Electric Utility Road Crossings	9
GVEC Trench Typicals	10-11
Bollard Specifications	12
Transformer and Pedestal Conduit Guidelines	13
Step 3- Contract & Invoice; Payment Window	14
Step 4- Pre-Construction Meeting & Site Prep	15

ADDRESSING, SERVICE REQUESTS AND METERING

Step 5- Developer/Builder Responsibilities	16
Requesting Service for Temp. Const. Meters	17-18
Requesting Permanent service	19

FIBER & ADDITIONAL GVEC SERVICES

Pre-Wire New Construction with GVEC Fiber	20
All Services Information	21

DELIVERING MORE

STEP 1

To begin electric design, these items must be submitted to GVEC by developer:

- ▶ Preliminary Plat to plats@gvec.org for review.
- ▶ Application for Residential or Commercial Development.
- ▶ Development Master Plan (if applicable) as PDF or DWG file with phasing layout.
- ▶ Digital copy of Unit Plat (PDF & DWG) showing layout of property, lot-lines (with dimensions), scale factor information, georeference information, drainage, street names, dedicated easements and any other underground facilities.
- ▶ Digital copy of the Utility Plans (PDF & DWG) and full construction plans (PDF).
- ▶ Plans should include MEP and meter panel breakout.
- ▶ Plans should also include wet utilities/any other utilities planned for the development, any drainage, grading, street and sidewalk typicals, retaining walls, carports, amenity centers or common areas. Any and all revisions should be communicated to GVEC ASAP.
- ▶ Digital copy of the property boundaries (KMZ) for mapping.
- ▶ Information concerning location and load requirements for any non-residential subdivision facility such as signage, sewer lift stations, HOA Amenity Centers and landscaping pedestals.
- ▶ \$6,000 Engineering Deposit (to be applied toward final invoice).
- ▶ Most current files for unit if any component of design changes. (Failure to do so may result in a re-design fee. These non-refundable fees will be at the discretion of GVEC on a case-by-case basis.)

***Note: Please refrain from recording Unit Plat with associated municipality until GVEC has verified that all easements are acquired for overhead and underground installation.**

APPLICATION FOR RESIDENTIAL OR COMMERCIAL DEVELOPMENT

Development Information

Proposed Subdivision Name: _____ Unit No.: _____ (if applicable)

Location Description / Nearest Intersection: _____

City: _____ County: _____ School District: _____

Location in City Limits: Yes No Total Number of Buildable Lots: _____

Single Family Mobile Homes Allowed? Yes No

Avg. Home Size (sq. ft.): _____ Size of Service Requested: _____

Multi Family Type: _____ No. of Proposed Units: _____

Commercial Type of Business: _____

Type of Electric Service Requested (check one): Underground Overhead

GVEC Construction Target Date: _____ Date for Service Requested: _____

Other Utilities to be included: (check all that apply)

Water Company Name: _____ Comms Company Name: _____

Sewer Company Name: _____ Comms Company Name: _____

Gas Company Name: _____ Other Company Name: _____

Sewer lift station service needed in development: Yes / No If yes: 3ph / 1ph Unit of lift station site: _____

Amenity Center service needed in development: Yes / No If yes: 3ph / 1ph Unit of Amenity Center lot: _____

Existing overhead line in conflict with unit: Yes / No Retaining walls in unit (location): _____

Owner Contact Information

Individual / Company Name: _____

Main Point of Contact: _____

Address: _____

City: _____ State: _____ Zip: _____

Telephone: _____ Email: _____ Fed. Tax ID#: _____

Engineer / Surveyor Contact Information

Individual / Company Name: _____

Main Point of Contact: _____

Address: _____

City: _____ State: _____ Zip: _____

Telephone: _____ Email: _____

***Note: Please return application along with final approved plat, CAD file, full civil plans and nonrefundable \$6,000 engineering deposit to initiate service. Deposit will be applied to final invoice.**



MULTI-FAMILY NOTES

- ▶ Multi-Family includes but is not limited to apartments, condos, townhomes, and duplexes.
- ▶ GVEC will own all primary line up to the point of the transformer.
 - The developer's electrician is responsible for sizing all secondary wire and installing all secondary wire from transformer to metering point.
 - The developer is responsible for coordinating the installation of all secondary conduit.
 - GVEC will land secondary wire inside of the transformer once the meter can is made up and has passed all necessary inspections. GVEC will own the meter itself.
- ▶ The developer's electrician is responsible for providing a master electrical plan for the development including a meter panel layout.
- ▶ The developer's electrician is responsible for labeling all meter cans with stenciled-on painted numbers.
- ▶ The developer's electrician is responsible for coordinating all necessary inspections with the proper city or county.
- ▶ Any rock excavation will be at an additional charge to the developer.
- ▶ The developer's engineer is responsible for any staking needed to complete the underground electric installation as well as providing the metes and bounds for any easements needed for GVEC.
- ▶ The developer will be responsible for full material and labor costs of the project that are incurred by GVEC as well as any overhead line extensions needed to serve the development.
- ▶ The developer's civil contractor is responsible for installing all crossings including road crossings and drainage crossings as specified within the GVEC design.
- ▶ Crossings are to be installed meeting all GVEC specifications as laid out in the crossing packet.
- ▶ GVEC will not provide lighting within a privately owned multi-family development.
 - GVEC can offer metering points to serve lighting and other necessary services.
- ▶ Project site must be to grade +/- 2 inches prior to GVEC mobilization for construction.

Multi-Family Spacing Requirements:

- ▶ 10' of easement required, centerline of trench. If facilities are installed within 10' of any sort of encumbrance (structure, curb, pavement) our UG is backfilled with flowable fill.
- ▶ Transformer placement is minimum of 10' from any building.
- ▶ No primary underground is to be installed under any permanent structure including carports.

MULTI-FAMILY INCLUSIONS AND EXCLUSIONS

Inclusions:

- ▶ Design and engineering of GVEC electric utility infrastructure
- ▶ Prepare construction drawing(s) for installation of facilities
- ▶ Trenching and backfill for installation of all conduit and equipment for primary electric distribution infrastructure
- ▶ Material and labor for installation:
 - All primary electric and fiber conduit and wire to GVEC equipment
 - Electric distribution equipment including: transformers, switchgear, sectionalizing enclosures, switches, and risers
- ▶ Scheduled inspections of any crossings needed as specified by the GVEC design

Exclusions:

- ▶ Secondary conduit and wire
- ▶ Hauling of any excess spoils, releveling/grading of easement or ROW after construction is complete
- ▶ Compaction density testing
- ▶ Excavation in rock (if required, additional fee will apply)
- ▶ Select backfill (flowable fill) or specialized compaction (additional fees apply)
- ▶ Establishing final grade of site prior to installation of facilities
- ▶ Survey and staking of site to identify property corners, offsets, easements and other required points as required for installation of underground and overhead facilities
- ▶ Joint trench and/or installation of any facilities for other utilities such as phone, CATV, communication, or gas
- ▶ Customer meter base and/or installation
- ▶ Removal of vegetation or any other obstruction in easement area(s) encumbering installation of GVEC facilities
- ▶ Lighting within a privately owned multi-family development
- ▶ Relocation of existing overhead electric facilities in conflict with proposed development (additional fee for relocation will apply)
- ▶ Bollard installation

STEP 2

Upon receipt of approved design from GVEC, developer's responsibilities include:

- ▶ Install all road crossings as displayed on GVEC "Approved for Construction" design.
- ▶ After placement of crossings, but before backfilling, developer must contact GVEC for road crossing inspection by emailing ugcrossings@gvec.org.
- ▶ Revision/replacement of road crossings, as needed, per inspection. Contract and invoice for GVEC installation will be provided at this stage of construction.

REQUIREMENTS FOR ELECTRIC UTILITY ROAD CROSSINGS

All road crossings must be installed according to GVEC's electrical design.

All road crossings must be inspected by a GVEC representative before being backfilled.

- ▶ All road crossing conduit material is supplied by developer.
- ▶ Only 2 ½-inch or 4-inch (as called for on approved design) Schedule 40 gray electrical conduit is to be used.
- ▶ All joints of placed conduits must be glued during installation.
- ▶ All road crossing conduits must be covered with red burial warning tape 12 inches above conduit.
- ▶ Road crossing conduits must be installed with minimum of 50 inches of cover at final grade.
- ▶ Conduits should be laid flat in the trench, side by side, as shown in the typical—*not* stacked or twisted. If more than two pipes are in a trench, they must be numbered on the inside, bottom of each pipe (ex: 1, 2, 3, etc.).
- ▶ 4-inch conduit, when called for, will be laid flat, side-by-side in the bottom of the trench. If more than two pipes are in a ditch, you must number the inside, bottom of each pipe (ex: 1,2,3, etc.). The 2 ½-inch may be stacked on top of the 4-inch with a minimum of 4 inches separation between them, but still require 48 inches of cover at final grade to the top set of crossing pipes.
- ▶ When electrical crossings are required to cross water mains, they must be 2 feet below or 2 feet above water mains. Conduits still require 48 inches of cover at final grade. (Pit sand may be required by some water utilities.)
- ▶ All other utilities must maintain a minimum of 3 feet of separation from the electrical crossing trench.
- ▶ No other utility crossings may be stubbed out in front of electric transformers or switches.
- ▶ No other utilities may share the same trench as the electric conduits.
- ▶ All crossings are to be installed at the property line unless water meters are at the crossing location. At locations where water meter conflicts exist, the electrical crossing must be moved 7 feet from the property line to avoid water meters. All other utility crossings must be located 3 feet on opposite side of property line.
- ▶ Crossings must be installed at all drainage channels.
- ▶ Property pins/stakes must be set at both ends of crossing for verification of correct location.

**ALL CROSSINGS MUST BE INSPECTED BY A GVEC REPRESENTATIVE BEFORE THEY ARE BACKFILLED.
PLEASE PROVIDE ONE WEEK NOTICE AS TO WHEN INSPECTIONS WILL BE NEEDED.**

SEND EMAIL TO UGCROSSINGS@GVEC.ORG TO SCHEDULE INSPECTIONS

SPANISH VERSION AVAILABLE UPON REQUEST

GVEC TRENCH TYPICALS

Typical Trench With
2 1/2" and 4" Conduits

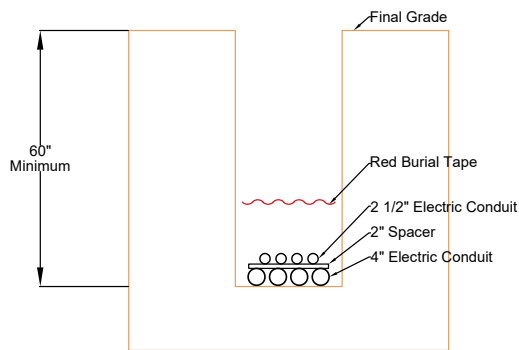

Typical Trench With
2 1/2" Conduits

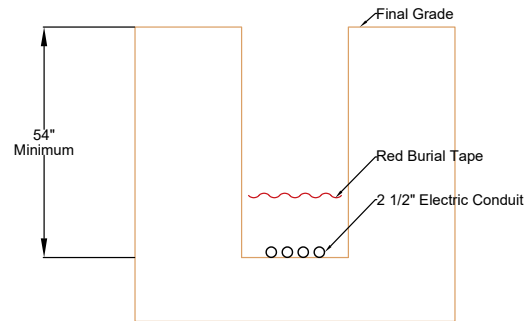

GVEC TRENCH TYPICALS

TYPICAL CROSSING
PLACEMENT AT
INTERSECTION

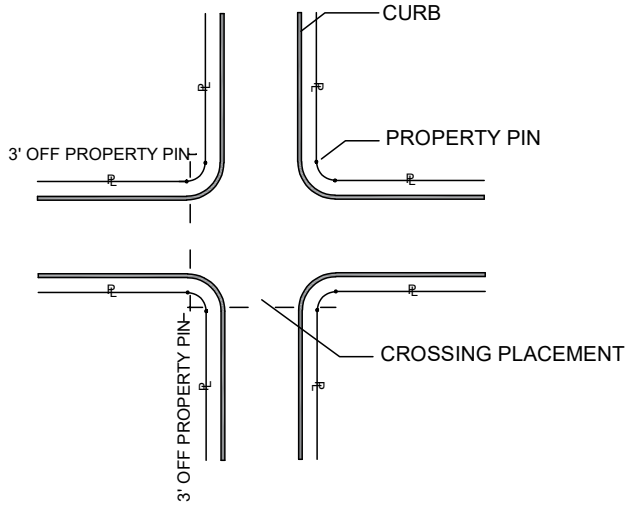

TYPICAL CROSSING
AT PROPERTY LINE WITH
NO WATER METERS OR FIRE PLUG

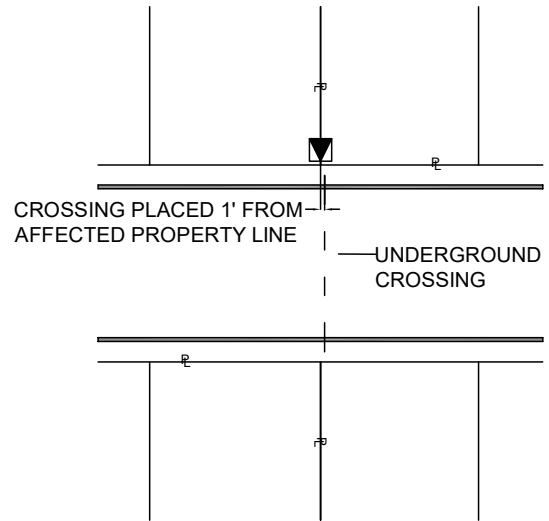

TYPICAL CROSSING
PLACEMENT AT
DRAINAGE OUTLET

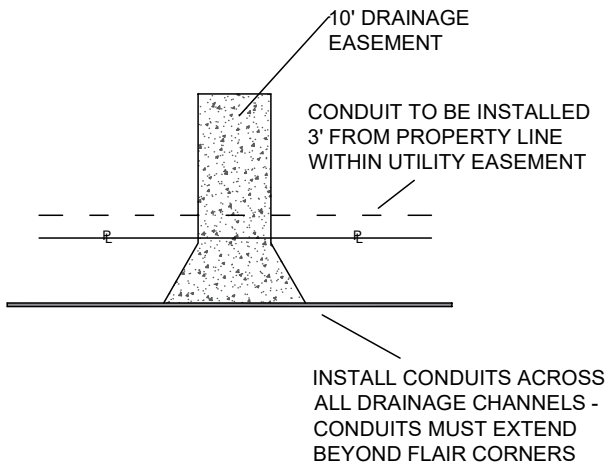

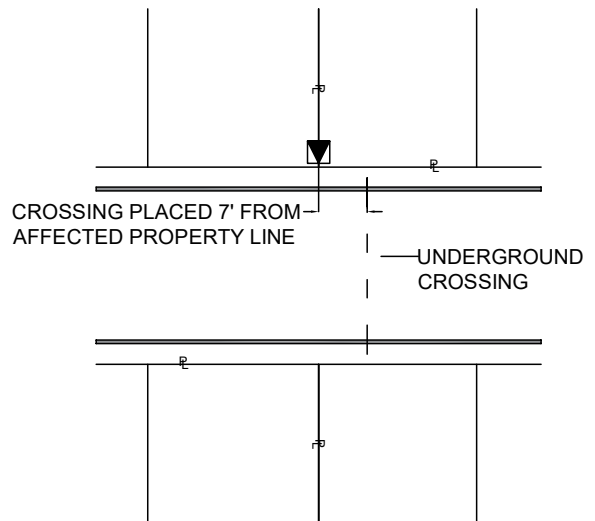

TYPICAL CROSSING
AT PROPERTY LINE WITH
WATER METERS OR FIRE PLUG

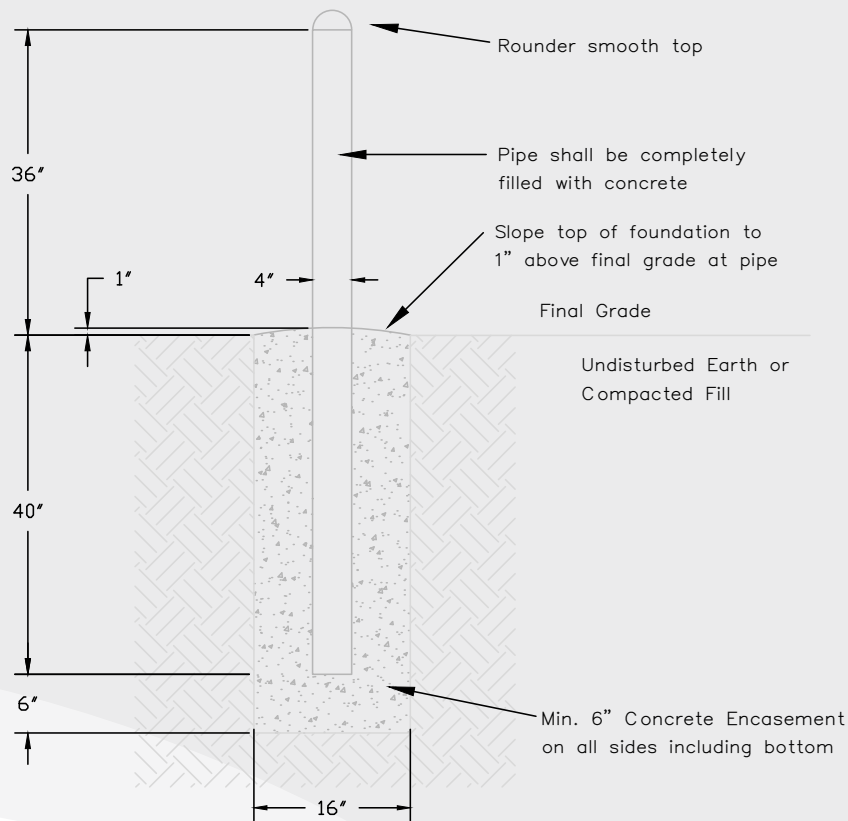

BOLLARD SPEC

Location of bollards shall be determined by GVEC
 Bollard shall be 4" in diameter and made of schedule 80 galvanized steel pipe.
 Concrete shall be a minimum of 3000 psi.
 Exposed portions of Bollards shall be finished with one coat of inhibitive primer
 and two coats of (Safety Yellow) epoxy paint.
 Bollard foundation shall be 18" diameter and 46" deep measured from final grade.



GUADALUPE VALLEY ELECTRIC COOPERATIVE				
EQUIPMENT PROTECTION BOLLARD				
 Delivering more. [™] INTERNET ELECTRIC HOME			BOLLARD	
DATE	REVISED BY	DATE		REVISED BY
9-14-2017	GB			

TRANSFORMER AND PEDESTAL CONDUIT GUIDELINES

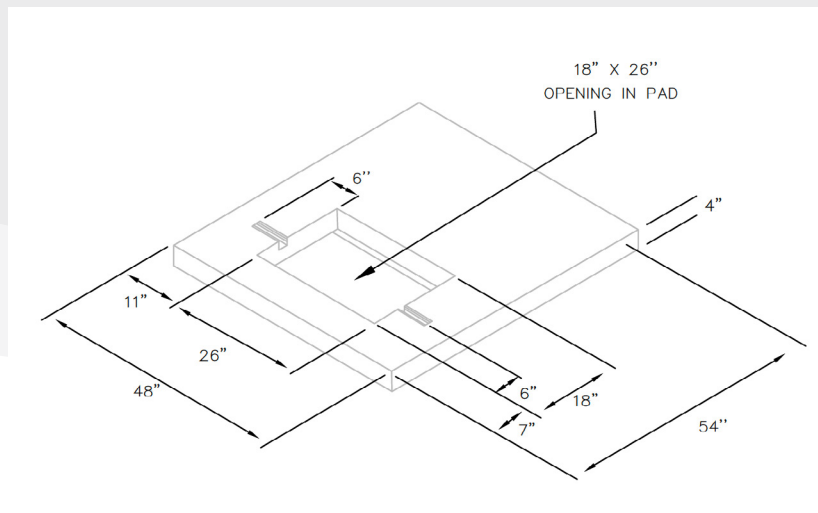
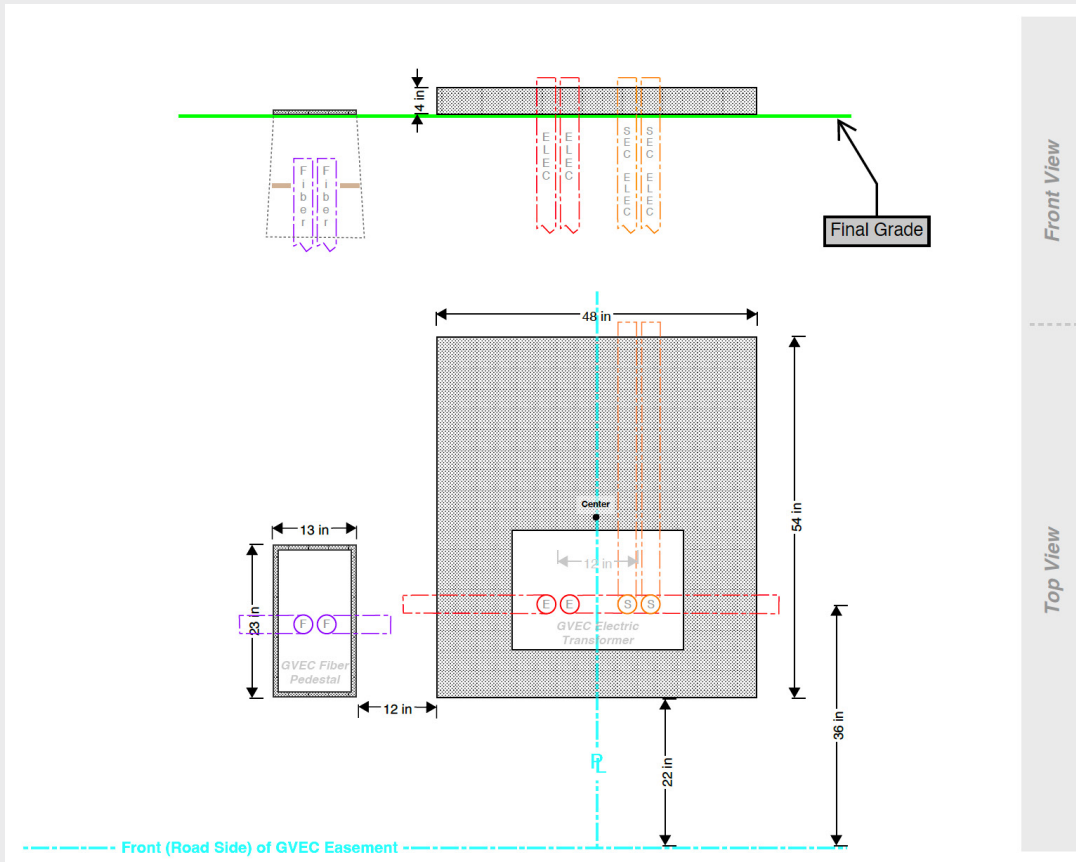

- ▶ No more than 8 - 2.5" or 3" conduit, with conductor not to exceed 500 MCM per any pad mounted transformer
- ▶ No more than 6 - 4" conduit, with conductor not to exceed 750 MCM per any pad mounted transformer
- ▶ No more than 2 - 2.5" or 3" conduit, with conductor not to exceed 4/0 per any flush mounted pedestal

gvec.org

gvec
Delivering more.

STEP 3

Upon completion of road crossing inspections or at the start of wet utilities installation (if crossings will not be required), GVEC will issue the contract and invoice and the developer's responsibilities include:

- ▶ Submit signed and notarized copy of contract.
- ▶ If applicable, complete Pre-Curb Agreement.
- ▶ Submit payment for installation as noted on agreement letter within 90 days of issuance.

STEP 4

To begin electric installation within the unit, developer must:

- ▶ Correspond with GVEC Project Coordinator to schedule pre-construction meeting with all stakeholders (30 days' notice required).
- ▶ Provide staking as noted by GVEC on exhibit provided at the time of construction.
- ▶ Provide suitable, daily access to construction site for GVEC and its contractors.
- ▶ Hold on-site pre-construction meeting with GVEC representatives and other stakeholders, as necessary.
- ▶ Contact GVEC Fiber to pre-wire new homes for fiber internet.

STEP 5

Developer/builder responsibilities to complete the project:

- ▶ Submit address list/address plat to GVEC Project Coordinator when issued by municipality. GVEC will not energize the subdivision unit until a copy of the recorded plat and addresses are received.
- ▶ Acknowledge notification of energization by email and/or phone call.
- ▶ Submit digital copy of recorded plat to GVEC Project Coordinator when filed with municipality (for plat signatures, email plats@gvec.org to coordinate signature). Please allow 2 business days for review and comments.
- ▶ Coordinate the installation of secondary conduit and wire installation with electrician and GVEC.

REQUESTING SERVICE FOR TEMPORARY CONSTRUCTION METERS

- ▶ Address must be acquired for each location prior to meter request.
- ▶ Request a temporary meter installation online through the [Developer & Builder Resources](#) page. Submit proof of passed inspection with the request, if required.
- ▶ Electrician to set approved temporary meter structure in proper location prior to request.
 - Proper location is immediately adjacent to transformer or pedestal providing power.
 - Temporary meter structure must be marked with address.
 - City inspection is required if within city limits.
- ▶ Once GVEC is notified of city inspection (where applicable), GVEC personnel will set temporary meter within 7-10 days.
- ▶ If temporary meter is deemed “out of spec” by GVEC lineman, a \$50 trip charge will be applied to account and meter must begin inspection process again.
- ▶ If energization and temporary service is required before the permanent service wire is installed into the transformers, the following standard operating procedure shall be observed. ***All equipment must be de-energized prior to having any non GVEC personnel enter any GVEC owned equipment***
- ▶ General contractor will call into GVEC and schedule a temporary disconnect for the associated transformer and or equipment that will need to be de-energized.
- ▶ GVEC personnel will de-energize all associated equipment, and leave the equipment open and unlocked.
- ▶ Electrician can then install the permanent service wire and complete any other necessary work.
- ▶ General contractor will need to call back into GVEC and request a reconnect when the electricians work has been completed.
- ▶ GVEC personnel will re-energize all associated equipment and will close and lock the equipment.
- ▶ Permanent meter installation will occur when the structure is complete, a permanent service application has been submitted, and applicable inspections are received.

TEMPORARY UNDERGROUND SERVICE DISTRIBUTION

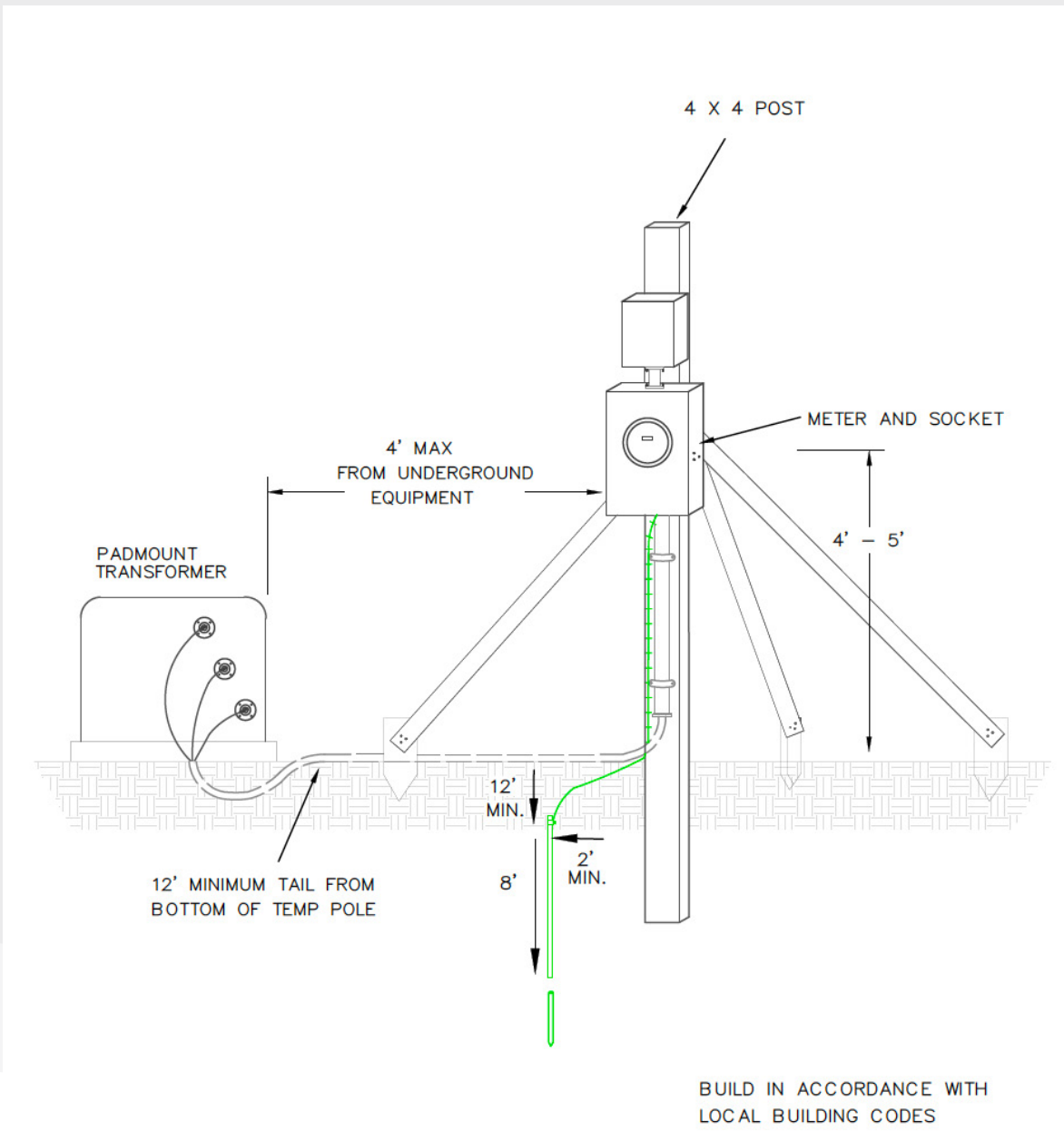

REQUESTING PERMANENT SERVICE

Permanent Meter

- ▶ After underground service is installed and the electrician has terminated the service wire in the meter base, the general contractor can request inspection based on city or county requirements.
- ▶ Meter panel should be mounted 3-6 feet from ground level and cannot be located behind fences and must be accessible at all times.
- ▶ Request a permanent meter installation online through the [Developer & Builder Resources](#) page. Submit proof of passed inspection (where applicable) with the request. GVEC personnel will set the permanent meter within 7-10 business days
- ▶ If meter can or service is deemed "out of spec" by GVEC personnel, a \$50 trip charge will be applied to account and necessary repairs or changes will need to be made prior to the permanent meter being set.
- ▶ If damage to GVEC facilities occurs during home construction, repairs must be made, and associated payment received prior to GVEC personnel setting permanent meter.

Exclusions:

- ▶ Secondary service line, meter base, main disconnects, or installation.
 - Electrician is responsible for terminating the service wire on the line side of the meter base.
 - Please consult Electric Line Layout/Service Location Plan for your specific subdivision.



Scan to visit the Developer & Builder
Resources Page at [gvec.org](https://www.gvec.org)

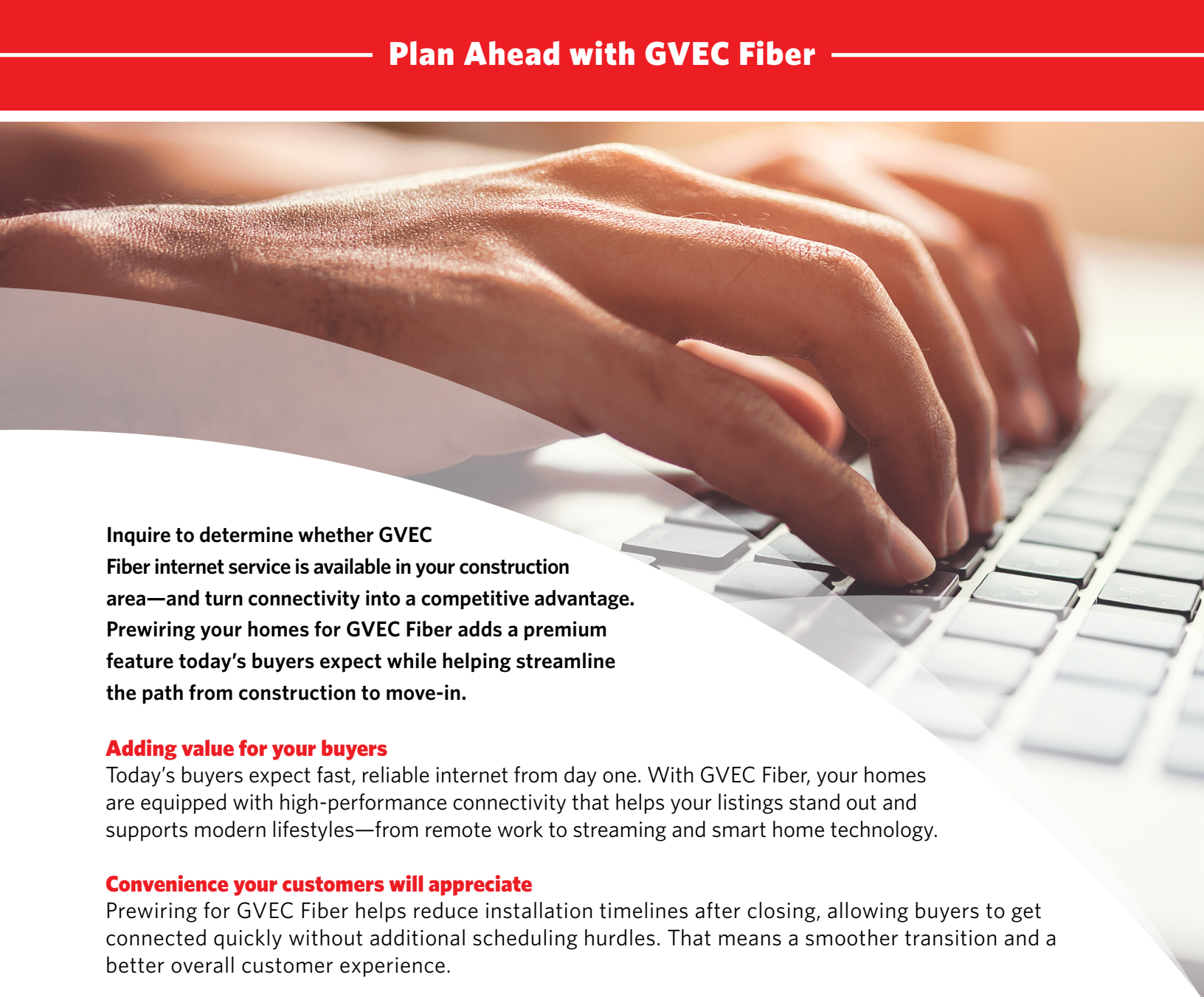

Inquire to determine whether GVEC Fiber internet service is available in your construction area—and turn connectivity into a competitive advantage. Prewiring your homes for GVEC Fiber adds a premium feature today's buyers expect while helping streamline the path from construction to move-in.

Adding value for your buyers

Today's buyers expect fast, reliable internet from day one. With GVEC Fiber, your homes are equipped with high-performance connectivity that helps your listings stand out and supports modern lifestyles—from remote work to streaming and smart home technology.

Convenience your customers will appreciate

Prewiring for GVEC Fiber helps reduce installation timelines after closing, allowing buyers to get connected quickly without additional scheduling hurdles. That means a smoother transition and a better overall customer experience.

Infrastructure built to last and for the future

GVEC Fiber-to-the-Home delivers consistent, dependable performance that's more reliable than other providers' copper-patched fiber connections. It's a long-term infrastructure investment that adds lasting value to your builds.

And, as customers' connectivity demands continue to grow, fiber provides the capacity to support whatever comes next—giving your homes a built-in advantage for years to come.

Call before the drywall

Contact GVEC three to five days before drywall installation to schedule fiber prewiring and ensure a seamless integration into your build timeline.

Build smarter, sell faster, and stand out—contact GVEC today to get Fiber built into your next project.

Email internetsupport@gvec.org to schedule.



Trust the energy efficiency experts to keep you running as efficiently as possible to save money today and for years to come.

- Commercial AC/heating sales and installation
- AC/heating repair
- Maintenance plans

Providing electricity in the Guadalupe Valley has been the core of who we are for over 80 years. Interested in saving money by generating your own power? Let us help!

- Solar sales and installation
- High-quality, affordable solar panels
- Weather-resistant panels
- 25-year warranty on products



We know the important role safe, reliable electricity plays in our lives. After years of requests from our electric members, we've now extended our 8 decades of expertise to you through our electrician services!

Contact us to discuss your commercial electrical needs.

We offer a variety of Internet plans to fit your business needs. There are no data limits, so you can accomplish the tasks you need to with no worries. Are you a large or industrial business that would benefit from a customized plan? Call us to request a quote!

- Wireless high-speed internet
- Extreme-speed fiber internet
- E-rate program for schools and libraries
- Fiber prewiring for single homes or home developments

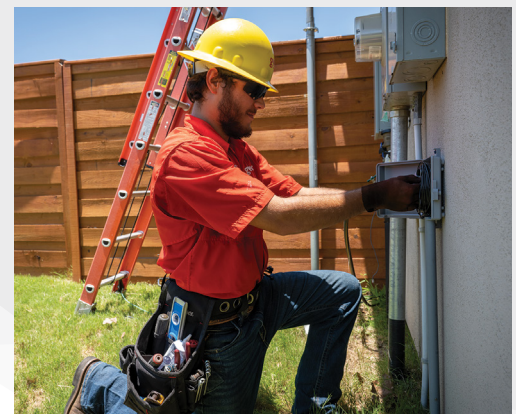

833.568.8801 | gvecACservice.com | gvecSOLARservice.com | gvecELECTRICIANservice.com
800.699.4832 | gvec.net

TACL00116382E | TECL32802

gvec.org

gvec
Delivering more.