

DELIVERING MORE.

SINGLE FAMILY RESIDENTIAL DEVELOPER'S PACKAGE

Unrivalled Quality and
Service Since 1938.

gvec.org

gvec
Delivering more.

ELECTRICITY

Internet | AC/Heating | Electrician Services | Solar & Battery | Community

WELCOME TO GVEC!

The Guadalupe Valley Electric Cooperative (GVEC) was founded in 1938 by a group of rural residents in the Cost area who needed electricity for their farms. On April 5, 1939, the Rural Electrification Administration approved the first loan to the Cooperative to be used in building rural electric lines. Construction began in May 1939, and eight months later, the first GVEC lines went into service.

GVEC provides affordable, reliable electric service to more than 100,000 rural, residential, commercial and industrial meters in South Central Texas. With headquarters in Gonzales and four area offices in the cities of Schertz, Seguin, La Vernia and Cuero, GVEC's service area spans 3,500 square miles across 13 counties. Through technological advancements, well-maintained systems and progressive planning, our goal is to continue to exceed member expectations—a goal we have focused on for over 80 years.

GVEC provides this packet to all developers and their agents, and it should be used as a guide in planning the installation of electric and fiber for receiving electrical power from GVEC's distribution system.

The information presented is subject to change and will be revised periodically to reflect any changes that may develop. Please refer to our website at gvec.org for additional information as well as an online version of this packet.

We look forward to working with you as your electricity provider. If you are looking to provide your customers with the most value from your developments, talk to us about our beyond the meter services including AC/Heating, solar and battery storage, electrician services, and high speed internet. We would appreciate the opportunity to help you beyond electricity!

Thank you,
The GVEC Development Group

TABLE OF CONTENTS

OVERVIEW & APPLICATION

Step 1 — Submittals to Initiate Electric Design	4
Application for Residential or Commercial Development	5

SCOPE OF WORK & DESIGN STANDARDS

Scope of Work Summary	6
Step 2 — Developer Responsibilities After Approved Design	7
Requirements for Electric Utility Road Crossings	8
GVEC Trench Typicals	9-11

CONTRACTS, PRE-CURB, AND PRE-CONSTRUCTION

Step 3 — Contract & Invoice; Payment Window	12
Step 4 — Pre-Construction Meeting & Site Prep	13-14

ADDRESSING, SERVICE REQUESTS, AND METERING

Step 5 — Developer/Builder Responsibilities	15
Requesting Temporary Construction Meters	16-17
Requesting Permanent Service — Underground Secondary Req	18
Requesting Permanent Service (Cont'd) — Permanent Meter	19-21

FIBER & ADDITIONAL GVEC SERVICES

Pre-Wire New Construction with GVEC Fiber	22
GVEC Commercial Services	23

DELIVERING MORE

STEP 1



To begin electric design, these items must be submitted to GVEC by developer:

- ▶ Preliminary Plat to plats@gvec.org for review.
- ▶ Application for Residential or Commercial Development.
- ▶ Development Master Plan (if applicable) as PDF or DWG file.
- ▶ Digital copy of Unit Plat (PDF & DWG) showing layout of property, lot-lines (with dimensions), scale factor information, georeference information, drainage, street names, dedicated easements and any other underground facilities.
- ▶ Digital copy of the Utility Plans (PDF & DWG). Plans should include wet utilities, any drainage and any other utilities planned for the development.
- ▶ Digital copy of full Civil Construction Plans (PDF) to GVEC showing grading, street and sidewalk typicals, and drainage structures throughout the unit.
- ▶ Digital copy of the property boundaries (KMZ) for mapping.
- ▶ Information concerning location and load requirements for any non-residential subdivision facility such as signage, sewer lift stations, HOA Amenity Centers and landscaping pedestals.
- ▶ \$6,000 Engineering Deposit (to be applied toward final invoice).
- ▶ Most current files for unit if any component of design changes. (Failure to do so may result in a re-design fee. These non-refundable fees will be at the discretion of GVEC on a case-by-case basis.)

***Note: Please refrain from recording Unit Plat with associated municipality until GVEC has verified that all easements are acquired for overhead and underground installation.**

STEP 1

APPLICATION FOR RESIDENTIAL OR COMMERCIAL DEVELOPMENT

Development Information

Proposed Subdivision Name: _____ Unit No.: _____ (if applicable)

Location Description / Nearest Intersection: _____

City: _____ County: _____ School District: _____

Location in City Limits: Yes No Total Number of Buildable Lots: _____

Single Family Mobile Homes Allowed? Yes No

Avg. Home Size (sq. ft.): _____ Size of Service Requested: _____

Multi Family Type: _____ No. of Proposed Units: _____

Commercial Type of Business: _____

Type of Electric Service Requested (check one): Underground Overhead

GVEC Construction Target Date: _____ Date for Service Requested: _____

Other Utilities to be included: (check all that apply)

Water Company Name: _____ Comms Company Name: _____

Sewer Company Name: _____ Comms Company Name: _____

Gas Company Name: _____ Other Company Name: _____

Sewer lift station service needed in development: Yes / No If yes: 3ph / 1ph Unit of lift station site: _____

Amenity Center service needed in development: Yes / No If yes: 3ph / 1ph Unit of Amenity Center lot: _____

Existing overhead line in conflict with unit: Yes / No Retaining walls in unit (location): _____

Owner Contact Information

Individual / Company Name: _____

Main Point of Contact: _____

Address: _____

City: _____ State: _____ Zip: _____

Telephone: _____ Email: _____ Fed. Tax ID#: _____

Engineer / Surveyor Contact Information

Individual / Company Name: _____

Main Point of Contact: _____

Address: _____

City: _____ State: _____ Zip: _____

Telephone: _____ Email: _____

***Note: Please return application along with final approved plat, CAD file, full civil plans and nonrefundable \$6,000 engineering deposit to initiate service. Deposit will be applied to final invoice.**



SCOPE OF WORK SUMMARY FOR GVEC INSTALLATION OF UNDERGROUND ELECTRIC IN SINGLE FAMILY RESIDENTIAL SUBDIVISIONS

Inclusions

- ▶ Design and engineering of GVEC electric utility infrastructure.
- ▶ Prepare construction drawing(s) for installation of facilities.
- ▶ Trenching and backfill for installation of all conduit and equipment for electric distribution infrastructure within utility easements.
- ▶ Material and labor for installation of:
 - All primary and secondary electric conduit and wire to GVEC equipment.
 - All electric distribution equipment: including transformers, switchgear, sectionalizing enclosures, switches, risers, secondary pedestals etc.
 - Service conduit (up to 60' total length) to meter location from transformer or secondary pedestal location (if longer distance required, additional fee will apply). A twenty foot (20') secondary service conduit stub-out will be installed in the initial installation for future extension to meter location on structure or dwelling.
 - Streetlights (as required by city franchise agreement).
- ▶ Scheduled inspections of road crossing conduit installation.

Exclusions

- ▶ Material and labor for the installation of any conduit or sleeves for utility infrastructure under roadways, or under any permanent drainage structure.
- ▶ Material and labor for the installation of any conduit or sleeves for utility infrastructure under existing underground pipelines or transmission facilities.
- ▶ Select backfill (flowable fill) or specialized compaction.
- ▶ Hauling of excess material or releveling/grading of easement or ROW after construction is complete.
- ▶ Compaction density testing.
- ▶ Boring under any roadways, drainage improvements, or existing utilities (if required, additional fee will apply).
- ▶ Excavation in rock (if required, additional fee will apply).
- ▶ Establishing final grade of site prior to installation of facilities.
- ▶ Survey and staking of site to identify property corners, offsets, easements and other required points as required for installation of underground and overhead facilities
- ▶ Joint trench and/or installation of any facilities for other utilities such as phone, CATV, communication, or gas.
- ▶ Customer meter base and/or installation.
- ▶ Removal of vegetation or any other obstruction in easement area(s) encumbering installation of GVEC facilities.
- ▶ Reinstallation of raceways or releveling of equipment due to changes in grade after installation of facilities.
- ▶ Relocation of existing overhead electric facilities in conflict with proposed development (Additional fee for relocation will apply).

STEP 2

Upon receipt of approved design from GVEC, developer's responsibilities include:

- ▶ Install all road crossings as displayed on GVEC "Approved for Construction" design.
- ▶ After placement of crossings, but before backfilling, developer must contact GVEC for road crossing inspection by emailing ugcrossings@gvec.org.
- ▶ Revision/replacement of road crossings, as needed, per inspection. Contract and invoice for GVEC installation will be provided at this stage of construction.

STEP 2

REQUIREMENTS FOR ELECTRIC UTILITY ROAD CROSSINGS

All road crossings must be installed according to GVEC's electrical design.

All road crossings must be inspected by a GVEC representative before being backfilled.

- ▶ All road crossing conduit material is supplied by developer.
- ▶ Only 2 ½-inch or 4-inch (as called for on approved design) Schedule 40 gray electrical conduit is to be used.
- ▶ All joints of placed conduits must be glued during installation.
- ▶ All road crossing conduits must be covered with red burial warning tape 12 inches above conduit.
- ▶ Road crossing conduits must be installed with minimum of 50" inches of cover from final grade to the top of the conduit.
- ▶ Conduits should be laid flat in the trench, side by side, as shown in the typical—*not* stacked or twisted. If more than two pipes are in a trench, they must be numbered on the inside, bottom of each pipe (ex: 1, 2, 3, etc.).
- ▶ 4-inch conduit, when called for, will be laid flat, side-by-side in the bottom of the trench. If more than two pipes are in a ditch, you must number the inside, bottom of each pipe (ex: 1,2,3, etc.). The 2 ½-inch may be stacked on top of the 4-inch with a minimum of 4 inches separation between them, but still require 48 inches of cover at final grade to the top set of crossing pipes.
- ▶ When electrical crossings are required to cross water mains, they must be 2 feet below or 2 feet above water mains. Conduits still require 48 inches of cover at final grade. (Pit sand may be required by some water utilities.)
- ▶ All other utilities must maintain a minimum of 3 feet of separation from the electrical crossing trench.
- ▶ No other utility crossings may be stubbed out in front of electric transformers or switches.
- ▶ No other utilities may share the same trench as the electric conduits.
- ▶ All crossings are to be installed at the property line unless water meters are at the crossing location. At locations where water meter conflicts exist, the electrical crossing must be moved 7 feet from the property line to avoid water meters. All other utility crossings must be located 3 feet on opposite side of property line.
- ▶ Crossings must be installed at all drainage channels.
- ▶ Property pins/stakes must be set at both ends of crossing for verification of correct location.

**ALL CROSSINGS MUST BE INSPECTED BY A GVEC REPRESENTATIVE BEFORE THEY ARE BACKFILLED.
PLEASE PROVIDE ONE WEEK NOTICE AS TO WHEN INSPECTIONS WILL BE NEEDED.**

SEND EMAIL TO UGCROSSINGS@GVEC.ORG TO SCHEDULE INSPECTIONS

SPANISH VERSION AVAILABLE UPON REQUEST



GVEC TRENCH TYPICALS

Typical Trench With
2 1/2" and 4" Conduits

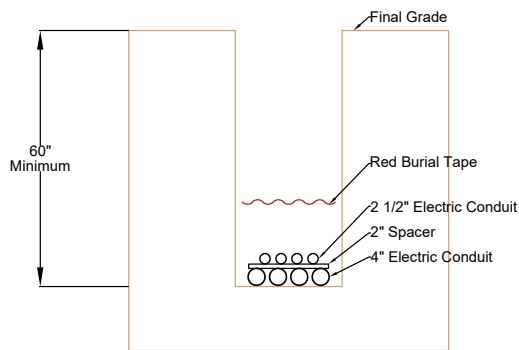

Typical Trench With
2 1/2" Conduits

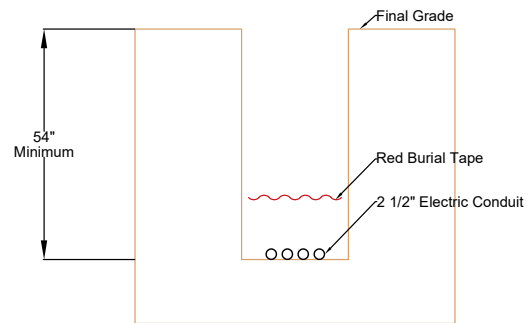

GVEC TRENCH TYPICALS

TYPICAL CROSSING
PLACEMENT AT
INTERSECTION

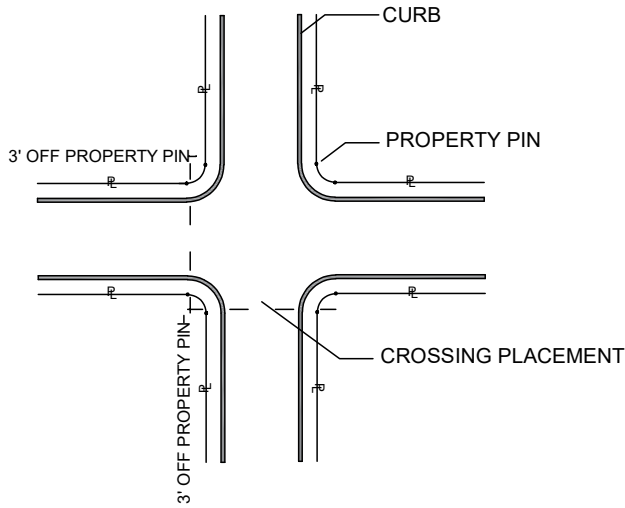

TYPICAL CROSSING
AT PROPERTY LINE WITH
NO WATER METERS OR FIRE PLUG

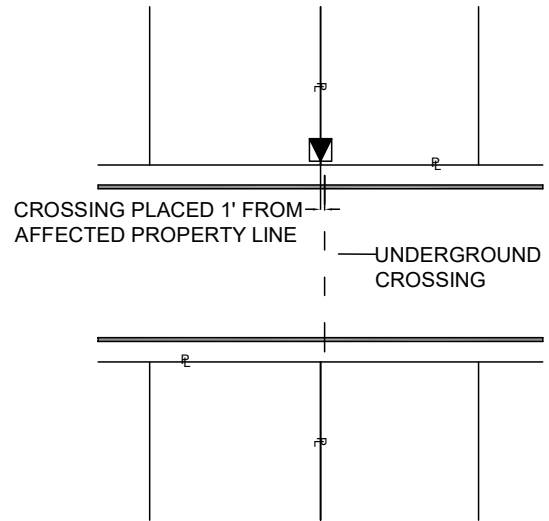

TYPICAL CROSSING
PLACEMENT AT
DRAINAGE OUTLET

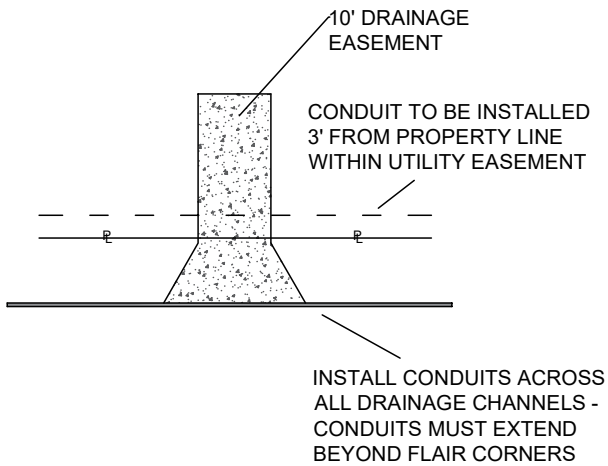

TYPICAL CROSSING
AT PROPERTY LINE WITH
WATER METERS OR FIRE PLUG

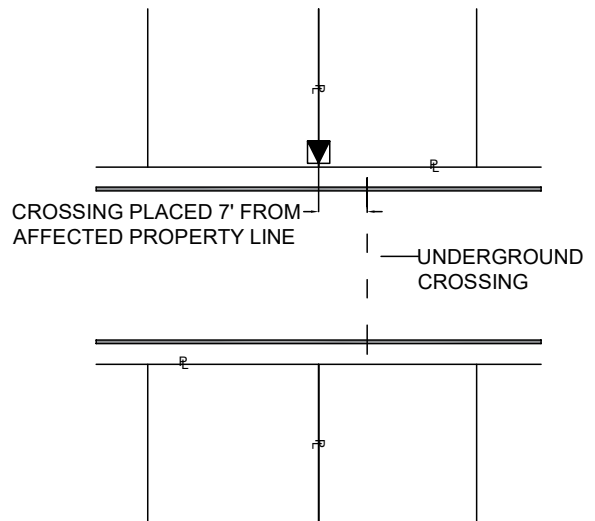

GVEC TRENCH TYPICALS

TYPICAL CROSSING
AT PROPERTY LINE WITH
PRIMARY AND SECONDARY CONDUITS

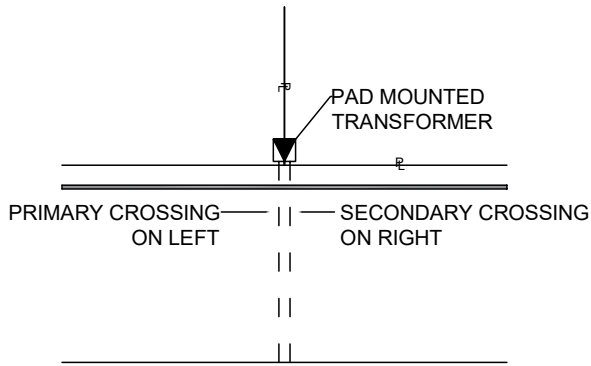

TYPICAL CROSSING
AT PROPERTY LINE WITH
PRIMARY CONDUITS

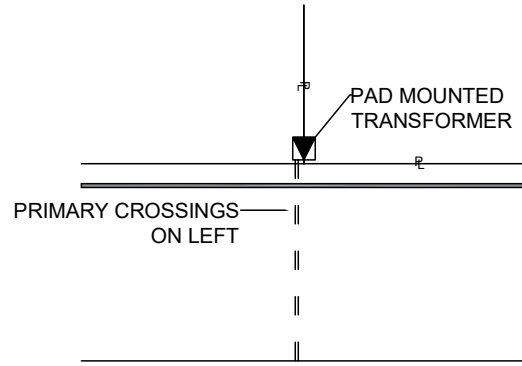

TYPICAL CROSSING
AT PROPERTY LINE WITH
SECONDARY CONDUITS

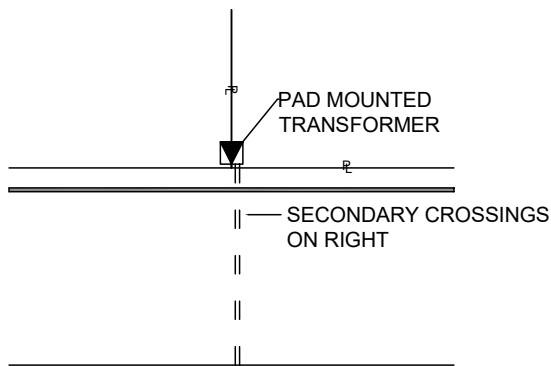

STEP 3

Upon completion of road crossing inspections, GVEC will issue the contract and invoice and the developer's responsibilities include:

- ▶ Submit signed and notarized copy of contract.
- ▶ If applicable, complete Pre-Curb Agreement.
- ▶ Submit payment for installation as noted on agreement letter within 90 days of issuance.

STEP 3

STEP 4



To begin electric installation within the unit, developer must:

- ▶ Correspond with GVEC Project Coordinator to schedule pre-construction meeting with all stakeholders (30 days' notice required).
- ▶ Provide lot staking with labeled laths that mark:
 - Front property line corners.
 - 30' offsets from property line corners.
 - Side lot/back lot corners as specifically requested.
 - Radius markers on curves (i.e., cul-de-sacs) as specifically requested.
- ▶ Provide suitable, daily access to construction site for GVEC and its contractors.
- ▶ Hold on-site pre-construction meeting with GVEC representatives and other stakeholders, as necessary.
- ▶ Contact GVEC Fiber to pre-wire new homes for fiber internet.

STEP 4

PRE-CONSTRUCTION MEETING PREREQUISITES

- All roads are to final grade.
- All easements are to final grade and clear of all obstructions.
- Staking for all property corners and offsets has been requested.
- Builders have been notified to keep utility easements clear of building materials and other obstructions.
- Water meter boxes or stub ups must be installed prior to underground electric installation.
- Water and sewer connections to home must not be installed until after electric installation is complete.
- Developer acknowledges that if any homes are started and water and sewer are connected prior to electric installation, GVEC and/or its assigned contractor will not be held liable for any damages that may occur. Developer also acknowledges that GVEC and/or its assigned contractor will not be responsible for damages of any building materials or other obstructions that may be placed in the easement.
- Developer acknowledges that installation of other dry utilities or connection of wet utilities to structures may entail added per-lot charges due to added labor charges during construction.
- If GVEC elects to begin construction prior to curb installation, a signed pre-curb agreement must be returned to GVEC.
- Completion and energization of system is subject to final inspection by GVEC representative.
- A representative from the developer, civil construction team, and engineering firm must be present at the in-person pre-construction meeting.

STEP 5

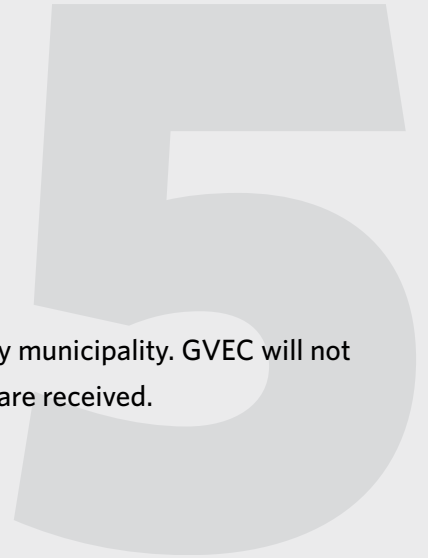

Developer/builder responsibilities to complete the project:

- ▶ Submit address list/address plat to GVEC Project Coordinator when issued by municipality. GVEC will not energize the subdivision unit until a copy of the recorded plat and addresses are received.
- ▶ Acknowledge notification of energization by email and/or phone call.
- ▶ Submit digital copy of recorded plat to GVEC Project Coordinator when filed with municipality (for plat signatures, email plats@gvec.org to coordinate signature). Please allow 2 business days for review and comments.
- ▶ Follow installation of Secondary Electric Conduit and Wire Requirements (as listed on page 17).
- ▶ Developer include the following in Home Owners' Association Bylaws:
 - *"Developer has requested and Utility has agreed to provide underground electrical distribution facilities, with Developer having approved the system design. Any request to subsequently relocate any portion of the underground facilities shall be consistent with the Utility's design and operating practices and the requesting party shall bear all costs associated with such relocation. All pad-mounted transformers shall have no less than ten (10) feet of unencumbered space in front of the transformer doors for operation and maintenance of the equipment. Utility is hereby granted access across property as necessary for maintenance and/or replacement of transformers and underground power lines. Utility shall only be required to fill, grade and restore ground cover back to original grade as a result of any excavation. Utility shall not be liable for payment or for repair of any damage to landscaping, shrubbery, fence, walk, patio, or driveway in connection with the installation, maintenance, or relocation of the underground electric system."*

STEP 5

REQUESTING SERVICE FOR TEMPORARY CONSTRUCTION METERS

- ▶ Address must be acquired for each location prior to meter request.
- ▶ Request a temporary meter installation online through the [Developer & Builder Resources](#) page. Submit proof of passed inspection with the request, if required.
- ▶ Electrician to set approved temporary meter structure in proper location prior to request.
 - Proper location is immediately adjacent to transformer or pedestal providing power.
 - Temporary meter structure must be marked with address.
 - City inspection is required if within city limits.
- ▶ Once GVEC is notified of city inspection (where applicable), GVEC personnel will set temporary meter within 7-10 days.
- ▶ If temporary meter is deemed “out of spec” by GVEC lineman, a \$50 trip charge will be applied to account and meter must begin inspection process again.



Scan to visit the Developer & Builder Resources Page at [gvec.org](https://www.gvec.org)

[gvec.org](https://www.gvec.org)

gvec
Delivering more.

TEMPORARY UNDERGROUND SERVICE DISTRIBUTION

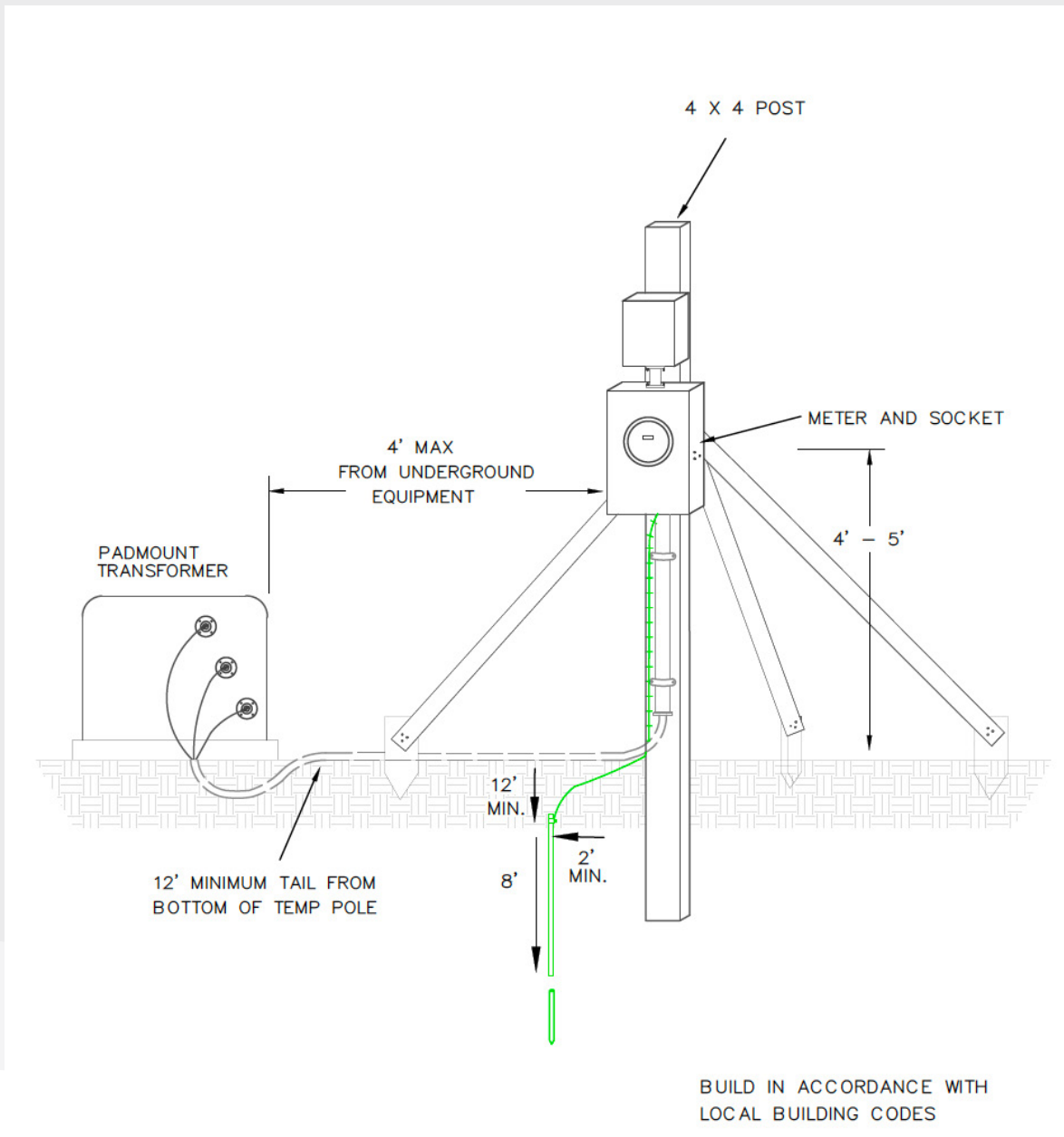

REQUESTING PERMANENT SERVICE

Underground Secondary

- ▶ Please request an As-built of your specific subdivision unit prior to beginning home construction, these documents will provide service entrance location for each lot.
- ▶ Request underground (secondary) installation online through the [Developer & Builder Resources](#) page. Submit a photo of installed electrical service on the home with the request.
 - We will accept pictures of the slab with the location of the electrical clearly marked, within 5' of the front of the slab. This coincides with our platted utility easement. If service is not where underground secondary is stubbed up, responsibility will lie with the contractor/electrician to move the service to meet our underground.
 - Requests will not be released to construction unless a photo is submitted.
- ▶ Photo of installed electrical service on the home must be submitted to meterrequest@gvec.org. Please include service address and contact information with submission.
 - We will accept pictures of the slab with the location of the electrical clearly marked, within 5' of the front of the slab. This coincides with our platted utility easement. If service is not where underground secondary is stubbed up, responsibility will lie with the contractor/electrician to move the service to meet our underground.
 - Requests will not be released to construction until a photo is received.
- ▶ Electrical service (Meter base and main disconnect switch assembly) must be installed on the side of the home nearest the pad mounted transformer or secondary pedestal that will serve the residence.
- ▶ Meter base shall not be located more than 5 feet back from the front corner of the house and shall not be located within a fenced area. (See typical on next page)
- ▶ If a meter base is installed prior to requesting underground, a slip coupling must be installed at the bottom of the meter base or installation will be refused. Conduit size is 2 ½" SCH 40 PVC.
- ▶ Easement area/right-of-way path for installation of service shall be clear of any building materials or obstructions prior to GVEC installing service conduit to the dwelling.
- ▶ Any concrete overpour from foundations must be cleared or chipped away to ensure that the conduit can be placed flat on exterior walls. Requires 12 inches of width clearance on anything above 3 feet deep.
- ▶ If gas service is present in your particular subdivision unit, gas service entrance stub out shall be placed on the opposite side of the dwelling from the Electric and communications service entrances.
- ▶ Failure to comply with the above requirements can result in fees and cancellation of request.

REQUESTING PERMANENT SERVICE (CONT'D)

Permanent Meter

- ▶ After underground service is installed and customer's electrician has terminated the service wire in the meter base, customer can request inspection based on city or county requirements.
 - Meter base must include a slip coupling to prevent separation or the meter installation will be refused. (Reference on page 19)
- ▶ Request a permanent meter installation online through the [Developer & Builder Resources](#) page. Submit proof of passed inspection (where applicable) with the request. GVEC personnel will set the permanent meter within 7-10 business days
- ▶ If meter can or service is deemed "out of spec" by GVEC personnel, a \$50 trip charge will be applied to account and necessary repairs or changes will need to be made prior to the permanent meter being set.
- ▶ If damage to GVEC facilities occurs during home construction, repairs must be made, and associated payment received prior to GVEC personnel setting permanent meter.

Inclusions:

- ▶ Material and labor for installation of:
 - Secondary electric conduit and wire to GVEC equipment
 - Service conduit up to 60' (sixty feet) total length to meter location from transformer or secondary pedestal location (if longer distance required, additional fee will apply).
 - A 20' (twenty foot) secondary service conduit stub-out will be installed in the initial installation for future extension to meter location on structure or dwelling.

Exclusions:

- ▶ Customer meter base and/or installation
 - Meter base and main disconnect switch assembly.
 - Customer is responsible for providing a slip coupling at the bottom of the meter base to prevent separation: conduit size is 2 ½" SCH 40 PVC.
 - Customer's electrician is responsible for terminating the co-op installed service wire on the line side of the meter base.
 - Please consult Electric Line Layout/Service Location Plan for your specific subdivision.



Scan to visit the Developer & Builder Resources Page at [gvec.org](https://www.gvec.org)

[gvec.org](https://www.gvec.org)

gvec
Delivering more.

SECONDARY METER INSTALLATION AND REQUIREMENTS

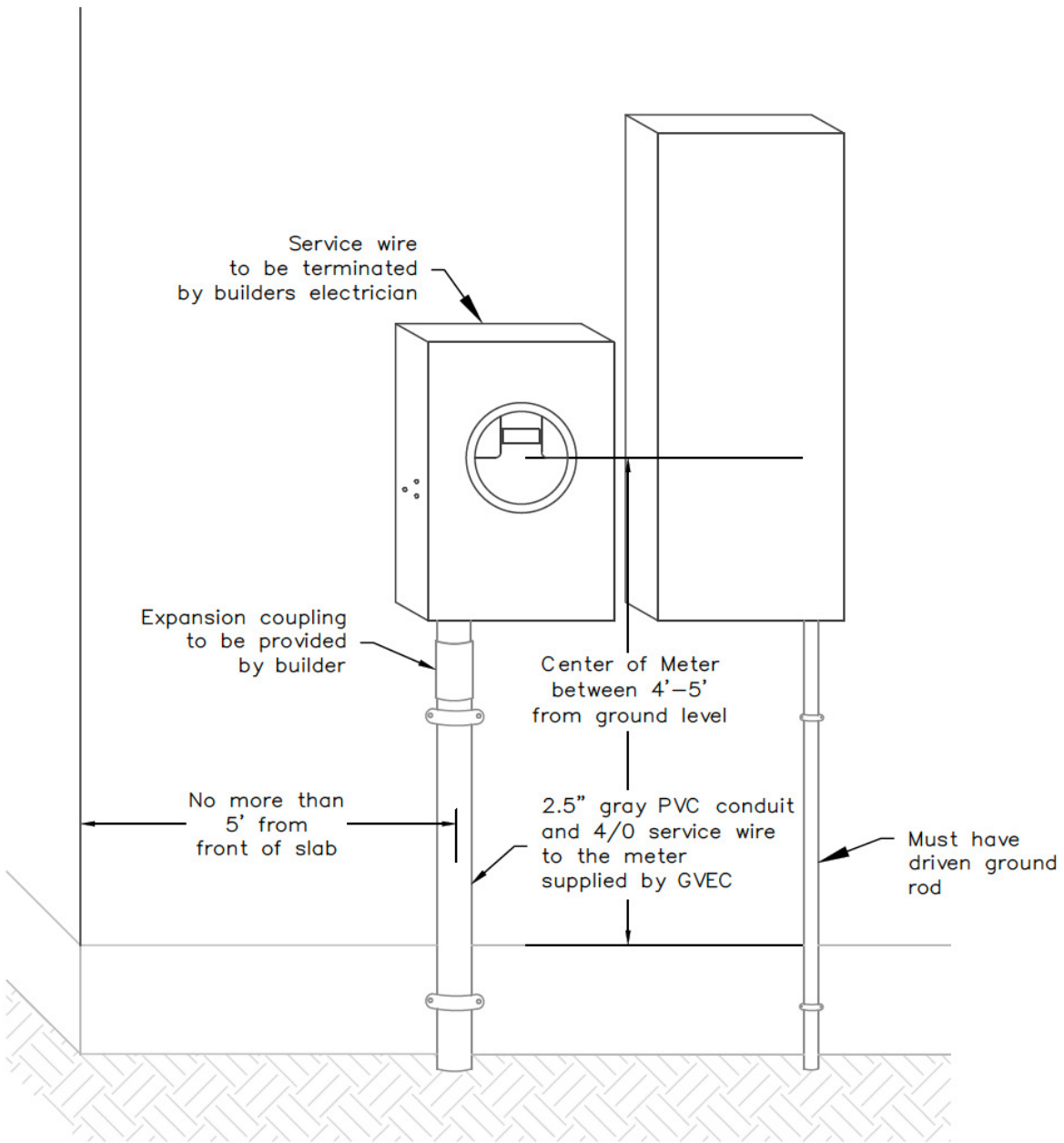

REQUESTING PERMANENT SERVICE (CONT'D)

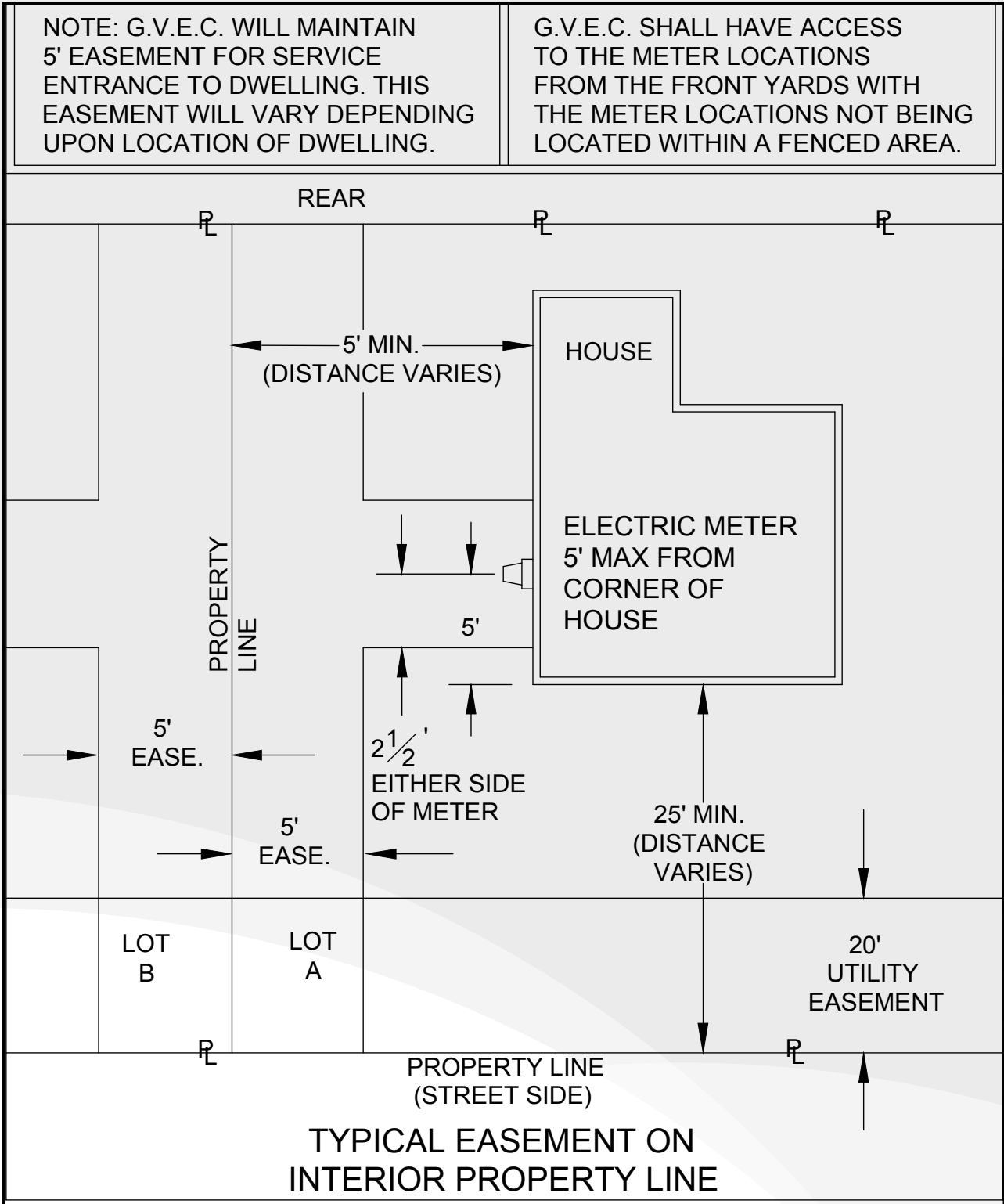

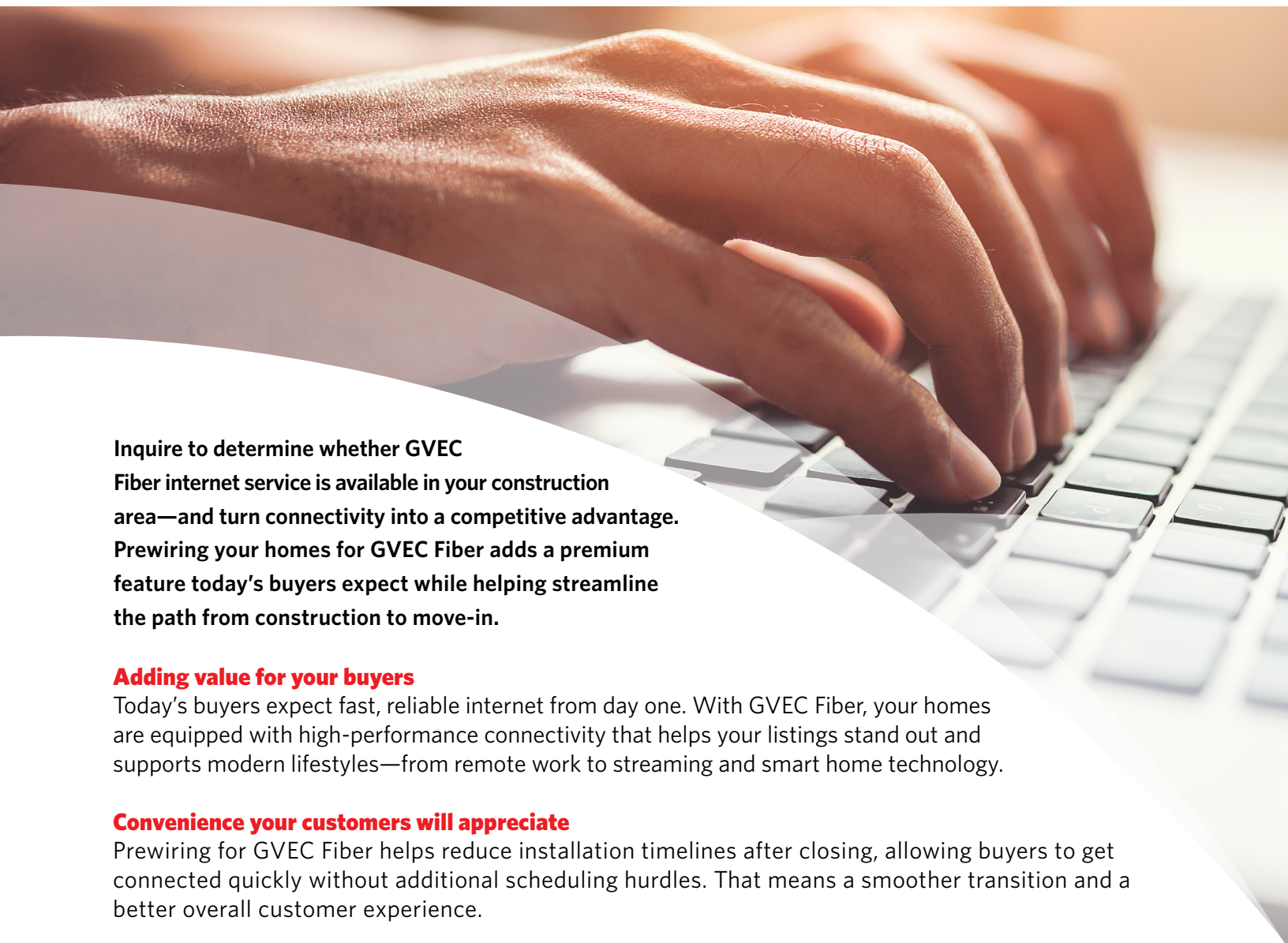

Inquire to determine whether GVEC Fiber internet service is available in your construction area—and turn connectivity into a competitive advantage. Prewiring your homes for GVEC Fiber adds a premium feature today's buyers expect while helping streamline the path from construction to move-in.

Adding value for your buyers

Today's buyers expect fast, reliable internet from day one. With GVEC Fiber, your homes are equipped with high-performance connectivity that helps your listings stand out and supports modern lifestyles—from remote work to streaming and smart home technology.

Convenience your customers will appreciate

Prewiring for GVEC Fiber helps reduce installation timelines after closing, allowing buyers to get connected quickly without additional scheduling hurdles. That means a smoother transition and a better overall customer experience.

Infrastructure built to last and for the future

GVEC Fiber-to-the-Home delivers consistent, dependable performance that's more reliable than other providers' copper-patched fiber connections. It's a long-term infrastructure investment that adds lasting value to your builds.

And, as customers' connectivity demands continue to grow, fiber provides the capacity to support whatever comes next—giving your homes a built-in advantage for years to come.

Call before the drywall

Contact GVEC three to five days before drywall installation to schedule fiber prewiring and ensure a seamless integration into your build timeline.

Build smarter, sell faster, and stand out—contact GVEC today to get Fiber built into your next project.

Email internetsupport@gvec.org to schedule.



Trust the energy efficiency experts to keep you running as efficiently as possible to save money today and for years to come.

- Commercial AC/heating sales and installation
- AC/heating repair
- Maintenance plans

Providing electricity in the Guadalupe Valley has been the core of who we are for over 80 years. Interested in saving money by generating your own power? Let us help!

- Solar sales and installation
- High-quality, affordable solar panels
- Weather-resistant panels
- 25-year warranty on products



We know the important role safe, reliable electricity plays in our lives. After years of requests from our electric members, we've now extended our 8 decades of expertise to you through our electrician services!

Contact us to discuss your commercial electrical needs.

We offer a variety of Internet plans to fit your business needs. There are no data limits, so you can accomplish the tasks you need to with no worries. Are you a large or industrial business that would benefit from a customized plan? Call us to request a quote!

- Wireless high-speed internet
- Extreme-speed fiber internet
- E-rate program for schools and libraries
- Fiber prewiring for single homes or home developments

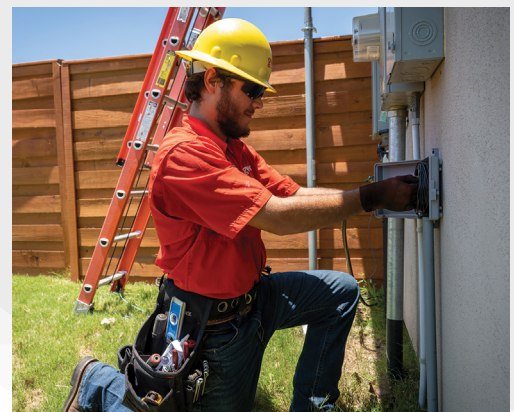

833.568.8801 | gvecACservice.com | gvecSOLARservice.com | gvecELECTRICIANservice.com
800.699.4832 | gvec.net